

THIS DRAWING IS UNPUBLISHED. RELEASED FOR PUBLICATION  
 © COPYRIGHT BY TYCO ELECTRONICS CORPORATION. ALL RIGHTS RESERVED.

LOC	DIST	REVISIONS					
FT	0	P	LTR	DESCRIPTION	DATE	DWN	APVD
		B		REVISED PER ECO-06-004471	11/18/08	SS	BC

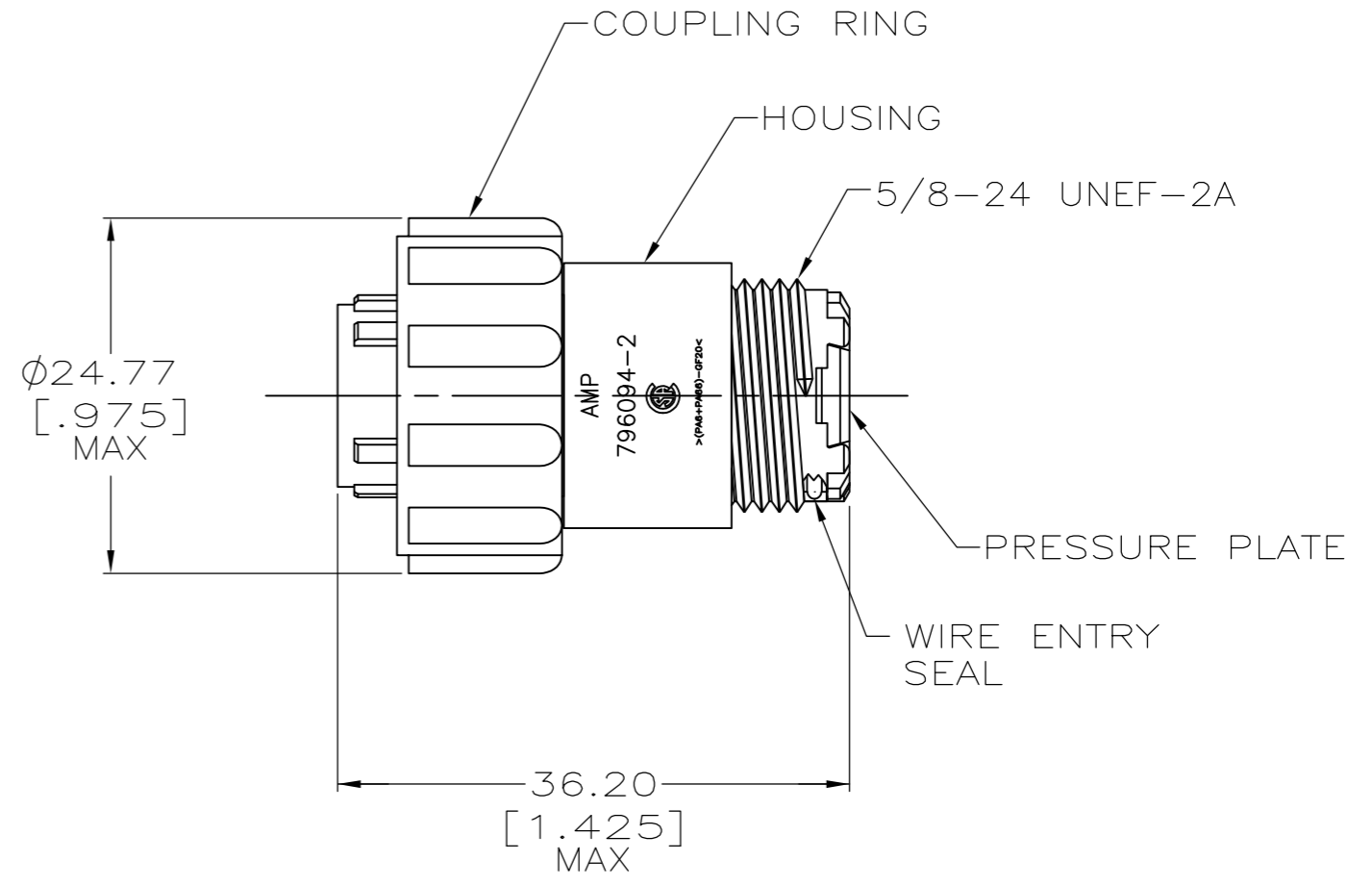
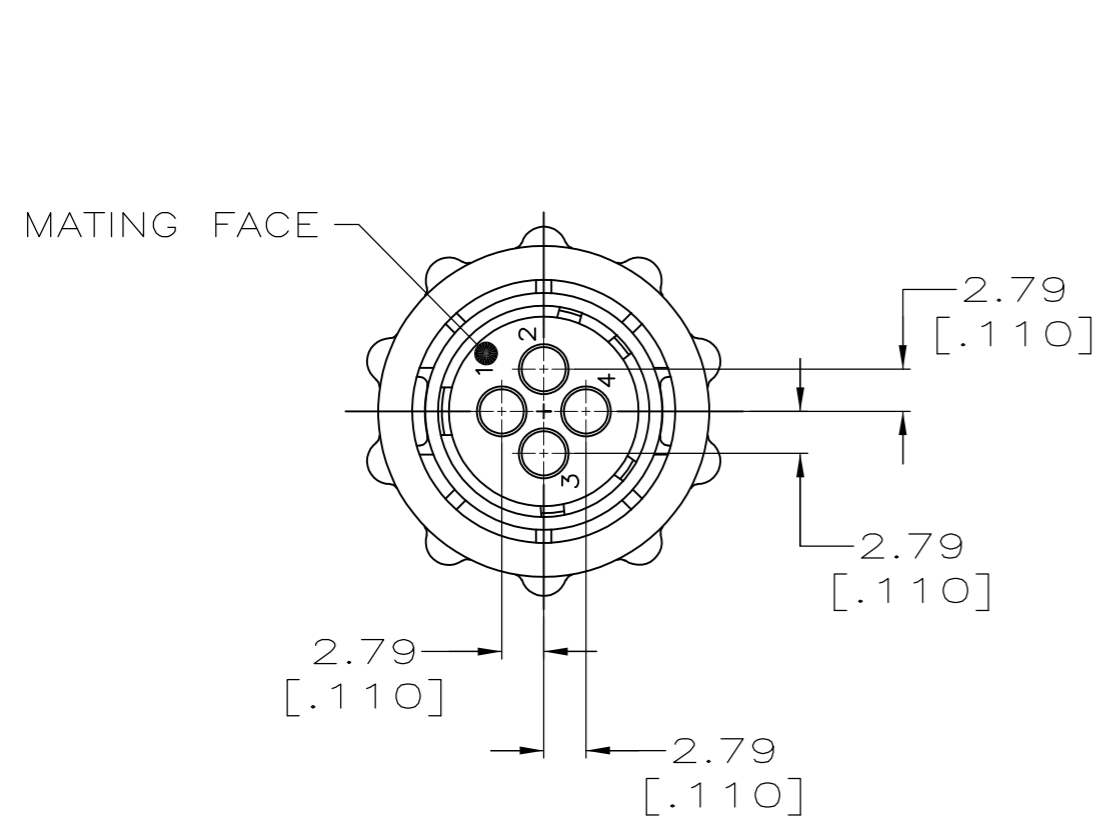

- 1. THIS PART WILL ACCEPT FOUR (4) MULTIMATE SOCKET CONTACTS.
- 2. COUPLING RING, HOUSING, AND PRESSURE PLATE: NYLON, BLACK. WIRE ENTRY SEAL: ELASTOMER, RED-IRON OXIDE.
- 3. PRELIMINARY PART NUMBER.

3	PULL FREE	796094-4
	METAL	796094-3
	STANDARD	796094-2
	COUPLING RING STYLE	PART NUMBER

THIS DRAWING IS A CONTROLLED DOCUMENT.		DWN C.DORWART 31 AUG 98	Tyco Electronics Corporation Harrisburg, PA 17105-3608													
DIMENSIONS: mm [INCHES]		CHK R.WALTER 31 AUG 98	NAME PLUG ASSEMBLY, 11-4, STANDARD SEX, SERIES I, SEALED, CIRCULAR PLASTIC CONNECTOR													
TOLERANCES UNLESS OTHERWISE SPECIFIED:		APVD R.WALTER 31 AUG 98														
<table border="1"> <tr><td>0 PLC</td><td>± -</td></tr> <tr><td>1 PLC</td><td>± -</td></tr> <tr><td>2 PLC</td><td>± 0.13 [.005]</td></tr> <tr><td>3 PLC</td><td>± -</td></tr> <tr><td>4 PLC</td><td>± -</td></tr> <tr><td>ANGLES</td><td>± -</td></tr> </table>		0 PLC	± -	1 PLC	± -	2 PLC	± 0.13 [.005]	3 PLC	± -	4 PLC	± -	ANGLES	± -	PRODUCT SPEC -	SIZE A3	CAGE CODE 00779
0 PLC	± -															
1 PLC	± -															
2 PLC	± 0.13 [.005]															
3 PLC	± -															
4 PLC	± -															
ANGLES	± -															
MATERIAL -		FINISH -	DRAWING NO C-796094	RESTRICTED TO -												
CUSTOMER DRAWING			SCALE 2:1	SHEET 1 OF 1												
			REV B													